



# Today's Bride<sup>®</sup>

WEDDING SHOW

# JUNE 7

**EMBASSY SUITES BY HILTON  
CLEVELAND - ROCKSIDE**

5800 Rockside Woods Blvd N.  
Independence, OH

SHOW HOURS: 11AM - 4PM

**EXHIBITOR RESOURCES**  
[TodaysBride.com/Pros/June](http://TodaysBride.com/Pros/June)

# Today's Bride®

WEDDING SHOW

Show Day Exhibitor Help **Hotline**  
**440-482-1055**

Need electricity? Trash overflowing?  
Music too loud? Call or text to report  
an issue without leaving your booth!

## Sunday, June 7, 2026

Embassy Suites by Hilton Cleveland-Rockside

We are pleased to present the Exhibitor Manual for the Cleveland Wedding Show on June 7, 2026.

Inside this manual, you'll have a record of important deadline dates, general guidelines, exhibitor rules, important exhibitor documents, and added-value promotional opportunities.

This entire manual, online forms, and additional helpful resources to prepare you for the show are available online at:

**NEW WEBSITE: [TodaysBride.com/Pros/June](http://TodaysBride.com/Pros/June)**

Please take the time to review the manual and website in their entirety, and share the information with your staff who will be setting up and/or working the show.

Thank you for being a part of the March Show! We are here to assist in any way we can before, during, and after the show. Don't hesitate to ask for our input on booth design ideas, marketing techniques, and more.

**OFFICE: 330-670-9545**

**Jennifer Judy** ext x14  
Direct: 234-285-3119  
Email: [jennifer@todaysbride.com](mailto:jennifer@todaysbride.com)

**Jim Frericks** ext x16  
Direct: 234-285-3117  
Email: [jim@todaysbride.com](mailto:jim@todaysbride.com)

**Abby Frericks Crowder** ext x12  
Direct: 234-285-3118  
Email: [abby@todaysbride.com](mailto:abby@todaysbride.com)

**Kay Grey** ext x22  
Direct: 234-285-3120  
[kay@todaysbride.com](mailto:kay@todaysbride.com)

**[www.TodaysBride.com/Pros/June](http://www.TodaysBride.com/Pros/June)**

## DEADLINES

### FRIDAY, MAY 15, 2026

Final Show Balance Due

### FRIDAY, MAY 22, 2026

Pink Stuff-It Bag Program Materials Due

Deliver or ship 400 flat pieces to the Today's Bride Office  
3550 Ridgewood Rd., Fairlawn, OH 44333

**Learn More:** [TodaysBride.com/pros/june-add](http://TodaysBride.com/pros/june-add)

### FRIDAY, MAY 29, 2026

Return Credentials Form

**Learn More:** [TodaysBride.com/pros/june-cred](http://TodaysBride.com/pros/june-cred)

### FRIDAY, MAY 29, 2026

Order Additional Booth Rental Items

Call Angel at Miller's Party Rental at 330-753-9104 or email  
[amk@millersparty.com](mailto:amk@millersparty.com) to reserve. Rental fees apply.

**Learn More:** [TodaysBride.com/pros/june-add](http://TodaysBride.com/pros/june-add)

### SUNDAY, JUNE 7, 2026

Vendor Move-In

**Time:** 8 AM - 10:45 AM (Silent opening at 10:45 AM!)

Show Hours

**Time:** 11 AM - 4 PM

<b>MOVE-IN HOURS</b>	<b>Sunday, June 7th</b>	8 AM - 10:45 AM No early move-in without prior approval from Today's Bride.
<b>SHOW HOURS</b>	<b>Sunday, June 7th</b>	11 AM - 4 PM There will be a silent opening of the doors to the public at 10:45 AM, so make sure your booth is ready to go!
<b>MOVE-OUT HOURS</b>	<b>Sunday, June 7th</b>	4 PM Vendors may begin to dismantle their booth display (no earlier than 4pm). <b>Beginning to tear down early is strictly prohibited and will result in a \$100 fine and forfeiture of the lead list!</b>
<b>EXHIBITOR ENTRANCE</b>	The main exhibitor entrance is on the <b>NORTH SIDE</b> of the building (right of the lobby). A Today's Bride Staff member will be there to greet you and give you your exhibitor packet and booth location.	

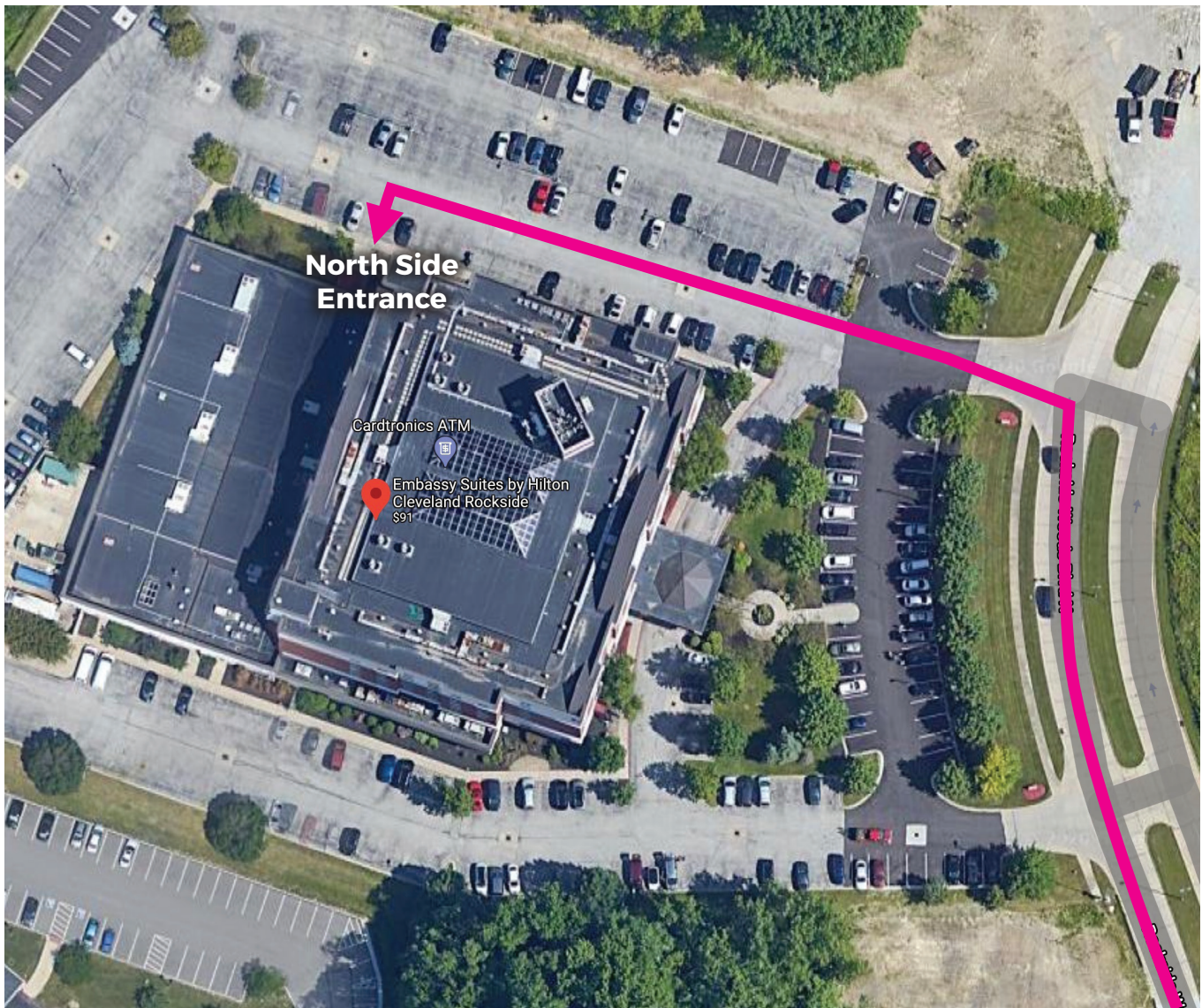

# Today's Bride®

WEDDING SHOW

Show Day Exhibitor Help **Hotline**  
**440-482-1055**

Need electricity? Trash overflowing?  
Music too loud? Call or text to report  
an issue without leaving your booth!

## MOVE-IN DETAILS

- ➔ Drive to the right side of the hotel and unload at the **NORTH SIDE** door. See map on page 3.
- ➔ A Today's Bride staff member will greet you and direct you to your booth, or to a better unloading area if needed. Exhibitors with only a few hand-carry items may come in the front lobby doors (no dollies or large equipment permitted).
- ➔ There will be some dollies available during move in, but we suggest bringing your own to ensure you have one while moving items to and from your booth space. No dollies will be provided during move out.

## MOVE-OUT DETAILS

- ➔ Vendors may begin to dismantle their booths at **4 PM**.
- ➔ Beginning to tear down early is **strictly prohibited** and will result in a \$100 fine and forfeiture of the lead list!

---

### FOOD SAMPLE GUIDELINES

Selling food products is not permitted. All sampling requests are to be submitted in writing in advance of the show. Sampling is limited to a 2-oz. portion for food and a 4-oz. portion for a beverage. The items being sampled must be part of your business services. No samples of any alcoholic beverages permitted.

---

### FOOD FOR STAFF

The hotel does not permit outside commercial food or deliveries to be brought into the facility. Concessions will be available from 10:30 AM – 3 PM. Please plan accordingly for your time onsite.

---

### PARKING

Parking is **FREE** in the Embassy Suites parking lot. Please park in the back of the hotel to save prime spots for show attendees.

---

### IDENTIFYING BRIDES

For easier identification, engaged attendees will be wearing a TODAY'S BRIDE sticker. If a couple is wearing a **GREEN STICKER** they still need a reception venue, and probably many other services. If a couple is wearing a **PINK STICKER**, they already have a reception venue.



HAS A RECEPTION VENUE



NEEDS A RECEPTION VENUE

---

### WI-FI

Hotel Meeting Room wi-fi is free. Join the **'Hilton Honors Meeting'** network.  
Password: **ESmtg19**



## PRE-SHOW PREP

### 12 weeks before the show:

- Download the Exhibitor Manual to prepare and track deadlines [TodaysBride.com/Pros/June](https://www.todaysbride.com/pros/june)

### Set Goals for the Show

- Number of appointments
- Testing a new product
- Taking deposits
- Signing contracts

### Plan your booth design

- Layout • Decor • Flooring
- Banners • Signage • Electric Access

- Order marketing materials: flyers, promo items, samples, show special to offer, literature for brides Pink "Stuff-It" Bags (if contracted)

### 4-6 weeks before the show:

- Order any extra rentals from a decorator, rental company, or venue
- Prepare a way to collect hot leads at the show (guest book, paper, or electronic forms)
- Pre-promote your presence at the show: share on social media, website, emails, voicemail & more
- Post online banner images promoting your booth and/or show special. Banners are located on the Exhibitor Manual website: [TodaysBride.com/Pros/June](https://www.todaysbride.com/pros/june)

### 3 weeks before the show:

- Stuff-it Bag Materials delivered to Today's Bride by **May 22, 2026**. Our address is **3550 Ridgewood Road, Fairlawn, OH 44333**.
- Proof your online listing on [TodaysBride.com](https://www.todaysbride.com)

- Audit your design & branding on your website and social media

### 1-2 weeks before the show:

- Submit your Sign & Nametag Credentials Form by **May 29, 2026**
- Submit your Show Special to post on [TodaysBride.com](https://www.todaysbride.com)
- Create a packing list of what to bring to the show (see right)
- Schedule & train your staff on booth etiquette, rules, the sales process, and show specials
- Plan parking and lunch options for your staff
- Prepare lead collection forms and the follow-up process (timing of phone calls, emails, direct mail, show special deadlines)
- Review the Exhibitor List online to strategize your networking

## POST-SHOW PREP

### After the show:

- Follow up on your hot leads from the show immediately
- Download the registered attendee list once alerted that it's available
- Continue working the leads throughout the attendees' engagement
- Renew the next show date to keep your online listing active

## PACKING LIST

- ♥ Electrical Cords & Surge Protector
- ♥ Mobile Device Chargers
- ♥ Sales Literature
- ♥ Business Cards
- ♥ Appointment Book
- ♥ Clipboards
- ♥ Booth Design Layout
- ♥ Dolly or Transporting Devices (Suitcase or Wagon)
- ♥ Masking Tape, Scotch Tape, Shipping Tape
- ♥ Scissors, Stapler, Safety Pins, Straight Pins
- ♥ Portable Vacuum/Steamer
- ♥ Pens, Sharpie Marker
- ♥ Trash Bags
- ♥ Aspirin, Band-Aids, Second Pair of Shoes
- ♥ Hand Sanitizer
- ♥ Lead Collection Forms (or laptop/tablet)
- ♥ Breath Mints
- ♥ Good Selling Plan & Attitude

# Today's Bride®

## WEDDING SHOW

### BOOTH REGULATIONS

#### INCLUDED WITH SINGLE FURNISHED BOOTHS & LARGER:

- 8' high BLACK back pipe & drape
- 3' high side rails to separate your booth from neighbors
- 6' rectangle table covered in standard BLACK linen
- 2 chairs, if needed
- Company Name Placement Sign
- Nametags for Staff

\*Tabletop booths include a covered 4' table with black linen and 1 chair.

\*Naked unfurnished booths do not include a covered table or chairs.

Below are the booth design regulation guidelines. For a SINGLE BOOTH, plan within a 9' x 8' due to vertical poles & bases taking up an extra foot.

NOTE: This Wedding Show has a variety of booth sizes that may differ than 9' x 8'. Contact your sales rep for specific dimensions.

1. Displays taller than 8' must get approval from Today's Bride 30 days prior to the show. The backdrop must be tastefully finished on the back side. Property or displays taller than 4' must be placed into the rear half of the exhibit space.

2. Pipes or trusses placed at the front of the booth space are acceptable provided the sides of the space do not obstruct the neighboring booth, and provided there is a clear line of sight from both sides.

Don't position retractable banners at the front of your booth space. Move halfway back or towards the back.

The front five feet of your exhibit may not exceed FOUR FEET in height, unless it's a see-through structure.

3. Stay within the space confines of your booth. Exhibitors are prohibited from standing in the aisles or having their booth displays extend into the aisles.

4. If you plan to uplight your booth backdrop, you must bring or rent your own pipe & drape backdrop to place in front of the drape that is shared with the exhibitor behind you. The light will show through the thin curtain.

If you are concerned your exhibit is not within the above guidelines, give us a call at 330-670-9545. If your exhibit isn't within the guidelines, you may be asked to make changes during move-in.

Exterior of any part of display facing a booth must be finished or suitably decorated.

Signage may not read into neighboring booths.

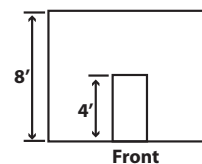
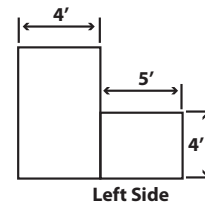
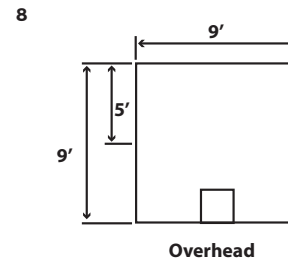
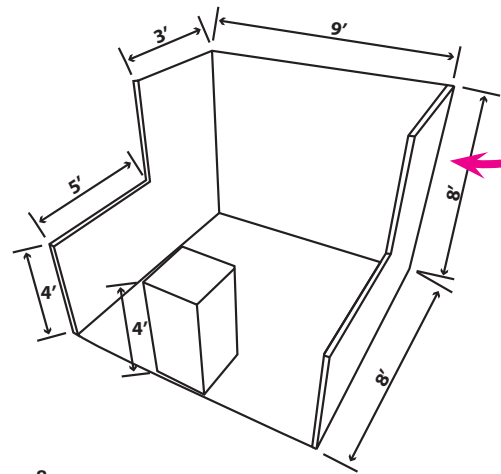

# THE RULES & REGULATIONS

**NOTE: It is your responsibility to understand and abide by these rules.**

Our insurance carrier and facilities instructed us to strictly enforce the show rules and regulations as indicated on your show contract. This will ensure a safe and enjoyable trade show experience not only for participating businesses but, more importantly, our valued attendees. Please read and adjust your presentation and set-up display if necessary.

**Review and share these guidelines with your staff scheduled to work your booth prior to the event.**

**1) Booth staff and all display materials must stay within their contracted booth space** and not infringe upon the aisle walkways or other booth spaces. All aisles must remain clear of obstruction. Maximum backdrop height is 8' tall. The front 5' of your booth may not exceed 4' in height unless the structure is see-through. Backdrops taller must get approval from Today's Bride. Some booth locations are restricted.

**2) Maximum of four staff members** are permitted to exhibit in a single booth space at one time. **Maximum of two staff members** permitted at one time in a Table Top Space.

**3) NO distribution** of any marketing materials is permitted in the event facility, outside of contracted booth space. This includes, but is not limited to: exhibit hall aisles, registration areas, seating areas, rest rooms, parking lot/garage or other event facility grounds.

**4) No helium balloons are allowed in the facilities.**

**5) Candles, votives or any item creating an open flame are not permitted inside the venue unless as an approved activity or exhibit.** All activities and/or exhibits with open flames require a minimum of seventy-two (72) hour advance notice, prior to the first Event date, for review and written approval from the Event Manager and Cleveland Fire Marshal (if applicable).

**6) Distribution of any non-participating, non-contracted business literature (business cards, brochures, signage, etc.) is strictly prohibited.** This includes, but is not limited to, photographs or displays with "courtesy of" acknowledgment of said businesses. The only exception is if the mentioned business is also an exhibitor at the current show.

**7) Distributing literature or displaying signage regarding a competing Bridal Show or Event** (whether at your facility or not) **is strictly prohibited** unless Today's Bride is a sponsor of the event.

**8) Exhibitors MAY NOT begin to take down their booth display prior to show close.** The take down, removal or repackaging of booth materials and/or displays during posted bridal show hours is strictly prohibited. Any set-up and disassembly must take place prior to guests' arrival and after their exit. You will be held accountable for any injury that may occur as result of your negligence, forfeit the show's lead list, risk approval to exhibit at future Today's Bride Shows, and be fined \$100. Additionally, guests pay admission for a show advertised with set hours of availability, and we must honor these hours.

**9) All food and liquids to be served as samples** must be approved by both the facility and Jadlyn Inc./Today's Bride at least two weeks before the show. Distribution of samples without prior approval is not permitted and may result in dismissal of exhibit space at the

show. Sample sizes are restricted to 2oz or less for food, 4oz or less for liquids. Alcohol is strictly prohibited. If using heat for samples, exhibitor must bring a Fire 10# ABC extinguisher to keep at said booth.

**10) Distribution of alcoholic beverages, in any form, to attendees is strictly prohibited.**

**11) All audio, video and/or gaming productions must be maintained at appropriate noise levels** so not to infringe on the peace and harmony of neighboring booths. Jadlyn Inc./Today's Bride reserves the right to determine and set the acceptable sound level. Exhibitor is responsible for compliance of all music licensing.

**12) Your company/businesses must provide its own surge-suppressant power strip and extension cord(s)** to use for your trade booth's electrical needs.

**13) The leads generated from this show are for the exclusive use of the exhibitors who made the investment to participate.** The lead lists are seeded. Today's Bride monitors what you are sending. It is a violation of your exhibitor agreement to sell, lend, reproduce, exchange, copy or share the lead list to any non-exhibiting business or non-sponsored show or event that isn't authorized for this list. If this information is used or threatened to be used in an unauthorized manner, Today's Bride shall be entitled to seek relief in any court of competent jurisdiction, including but not limited to injunctive relief, actual and punitive damages, reasonable attorney's fees, costs and any and all other expenses. It is also a violation to use the list or permit the list to be used to promote any other multi-business bridal- or wedding-related show or event, including Client's own participation within such an event, and that damages to Today's Bride for each such use shall be no less than \$3,000.00. (A "use" shall mean each letter, mailing or e-mail sent to an attendee on the lead list). Upon breach of this Contract for any reason, exhibitor's license to use such Lead List shall cease immediately.

**14) Exhibitor shall make good any damage to the building or fixtures caused by exhibitor or any of exhibitors' agents or employees.** Exhibitors are responsible for any loss of their equipment and/or display material, or personal belongings, resulting from accidental breakage, misplacement, theft, fire or natural disaster, including, but not limited to, damage occurring while Management staff is assisting an exhibitor. If exhibitor uses the services of Management staff, then exhibitor agrees that the staff member is a volunteer for the exhibitor for worker's compensation purposes.

**15) The Exhibitor is responsible for insuring its exhibit, personnel, display, automobiles, trailers, and materials against any damage or loss resulting from theft, fire, accidents, or any other cause.** The Exhibitor acknowledges and assumes all risks associated with the use of the exhibit space and its surroundings. The Exhibitor agrees not to make any claims, demands, or legal actions against Today's Bride/Jadlyn, Inc, the Show sponsors, or the facility hosting the Show for any loss, damage, or injury incurred by the Exhibitor, its officers, directors, agents, representatives, employees, or their respective property. Neither Today's Bride/Jadlyn, Inc. nor the facility will be liable for the loss or damage of equipment, products, goods, exhibits, or other materials owned, rented, or leased by the Exhibitor, regardless of the cause.

**These and all existing regulations will be strictly enforced. Violation to regulations may result in the exclusion from future trade shows and/or forfeiture of trade show lead list.**

# MARKETING UPGRADES

**PINK STUFF-IT BAG PROGRAM \$250\*** DEADLINE MAY 22, 2026



Guarantee every couple goes home with your marketing literature, whether you talked to them or not, by having your literature pre-stuffed in every pink welcome bag. All you need to do is supply us with **400 flyers** by **May 22, 2026**.

**Ship or drop flyers off at:**  
Today's Bride, 3550 Ridgewood Road Fairlawn, Ohio 44333

- Payment must accompany flyers. • Limited availability for some categories (call for details).
- The flyers **CANNOT** contain names or phone numbers of non-show participating exhibitors.
- The flyers **CANNOT** advertise another bridal show (at your facility or elsewhere).
- The flyers **CANNOT** exceed 10 pages. No magazines allowed.
- All flyers must be a single piece item and FLAT (call for approval of anything else).

\*must be an exhibitor to qualify for this discounted price.

## TICKET SPONSORSHIPS\*

Elevate your visibility at the show by sponsoring our online ticket sales! Your company logo will be prominently displayed and linked to your website across multiple pages as couples purchase their tickets. This opportunity not only enhances awareness of your presence at the show but also drives traffic to your website leading up to the event!

**PRIMARY DISCOUNT SPONSOR \$800**

**SECONDARY ONLINE SPONSOR \$400**

\*LIMITED SPACE AVAILABLE

## WEBSITE

TodaysBride.com is averaging 16,000+ visitors a month. Traffic increases 30% more before & after the shows. **NEW THIS YEAR!** You have the ability to update your online profile on TodaysBride.com. Visit [www.TodaysBride.com/Dashboard](http://www.TodaysBride.com/Dashboard) and log in with your credentials. Under "Listings" you will see your online profile. Click "Edit" to make any changes. *Make sure to update your photo and weblink!*

## FEATURED EXHIBITOR AD \$150

Secure prime placement on the bridal show page with a rotating banner linked to your online profile. Banners are live from date of purchase through the show date.

## FEATURED HOME PAGE PARTNER AD \$150

Secure prime placement on the TodaysBride.com home page with a rotating slider linked to your online profile + website.

Banners are live for one month after purchase.

We also have different levels of online profiles you can upgrade to, social media promotions, and eblast options available for exhibitors. Please contact [shows@todaysbride.com](mailto:shows@todaysbride.com) to learn more about availability and pricing.

To order the pink bag stuff-it program, ticket sponsorship, or online upgrades, please visit [TodaysBride.com/pros/june-add](http://TodaysBride.com/pros/june-add)



## ATTRACT COUPLES TO YOUR BOOTH WITH A **SHOW SPECIAL**

Show specials are a win-win for both couples & exhibitors at wedding shows! Attendees benefit by scoring deals and saving money, while exhibitors benefit by attracting more attention to their booth. Increase your chance of standing out, generating interest, and getting more leads by offering a limited-time show special.

### NEED INSPIRATION?

#### DO YOU WANT SIGNED CONTRACTS?

- ♥ Book today for 10% off
- ♥ Sign this week to save \$100
- ♥ Book this week for only \$1,200
- ♥ Receive a free photo album when you book at the show

#### DO YOU WANT MORE BOOTH VISITORS?

- ♥ Spin the wheel for an instant gift
- ♥ Play Plinko for a discount
- ♥ Listen to our demo for a free koozie
- ♥ Stop by our booth for a free catering or cake sample

#### DO YOU WANT TO COLLECT MORE LEADS?

- ♥ Enter to win \$500 off any package
- ♥ Enter to win a free overnight stay
- ♥ Schedule an appointment to get \$75 off your gown
- ♥ Enter to win \$200 with any purchase

Let us know about your show promotion and we'll help get the word out by:

- Posting it on the show page on [TodaysBride.com](http://TodaysBride.com).
- Several will be mentioned in an email blast promoting the show and shared on social media

**EMAIL YOUR SPECIALS TO  
[ABBY@TODAYSBRIDE.COM](mailto:ABBY@TODAYSBRIDE.COM)**

or submit it with your credentials form at  
[todaysbride.com/pros/june-cred](http://todaysbride.com/pros/june-cred)

### PROMOTE YOUR SPECIAL ON SOCIAL MEDIA

Follow us on:



**TAG us @todaysbride**  
so we can reshare!

# EXHIBITOR SERVICES

## AMAZON FAVORITES & SIGNS

Check out our Exhibitor Favorite Products on our amazon storefront:  
**Todaysbride.com/pros/favorite-products**

Items such as tables, tape, carts, & custom design signs/backdrops.

Availability and turnaround is dependent on scheduled production at time of order.



For more samples & ideas visit  
**Todaysbride.com/pros/favorite-products**  
or email [shows@todaysbride.com](mailto:shows@todaysbride.com)



## RENTALS

Miller's is the official decorator for the Today's Bride Wedding Show, offering discounted pricing on various rental items. The items will be placed in your booth space before the show unless you prefer to pick them up at their warehouse beforehand.



Call **330-753-9104**  
Angel, [amk@millersparty.com](mailto:amk@millersparty.com)  
with any questions and to place your order. Deadline to order is Friday **May 29, 2026**.

## PRINT



Looking for help with design and print of show materials? Today's Bride can help you with business cards, brochures, postcards, & more!



**330-670-9545**

Availability and turnaround is dependent on scheduled production at time of order.

## EXHIBITOR WEBSITE

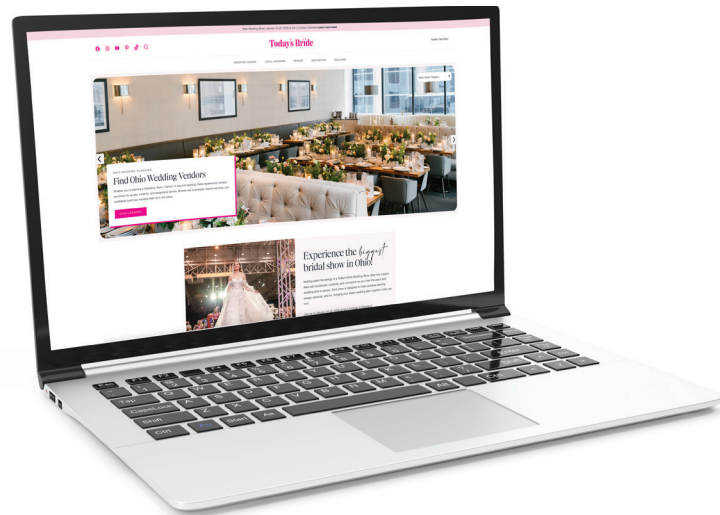

Please find this manual in its entirety plus deadlines, forms, inspiration, and helpful links at

**TODAYSBRIDE.COM/PROS/JUNE**

## We appreciate you taking the time to review the Exhibitor Manual.

We are here to help you any way we can before, during and after the show. Don't hesitate to ask for our input on booth design ideas, marketing techniques and more. **330-670-9545** or [shows@todaysbride.com](mailto:shows@todaysbride.com)

**Jennifer Judy x14**  
[jennifer@todaysbride.com](mailto:jennifer@todaysbride.com)

**Kay Grey x22**  
[kay@todaysbride.com](mailto:kay@todaysbride.com)

**Jim Frericks x16**  
[jim@todaysbride.com](mailto:jim@todaysbride.com)

**Abby Frericks Crowder x12**  
[abby@todaysbride.com](mailto:abby@todaysbride.com)