



Today's  
Bride<sup>®</sup>

WEDDING SHOW

Sunday,

**NOVEMBER 16**

**2025**

**Summit County Fairgrounds Arena**

1050 North Avenue • Tallmadge, OH

**EXHIBITOR MANUAL**

[pros.TodaysBride.com/November](https://pros.TodaysBride.com/November)

# Today's Bride®

## WEDDING SHOW

**Sunday, November 16, 2025**  
**Summit County Fairgrounds Arena**  
Show Hours: 11:00 AM - 4:00 PM

Show Day Exhibitor Help **Hotline**

**440-482-1055**

Need electricity? Trash overflowing?  
Music too loud? Call or text to report  
an issue without leaving your booth!

### We are pleased to present the Exhibitor Manual for the Summit County Fairgrounds Show on November 16, 2025.

Inside this manual, you'll have a record of important deadline dates, general guidelines, exhibitor rules, important exhibitor documents, and added-value promotional opportunities.

This entire manual, online forms, and additional resources to help prepare you for the show are available online at:

**[Pros.TodaysBride.com/November](https://pros.TodaysBride.com/November)**

Please take the time to review the manual and website in its entirety, and share the information with your staff who will be setting up and/or working the show.

Thank you for being a part of the November Show! We are here to help you in any way we can before, during, and after the event. Don't hesitate to ask for our input on booth design ideas, marketing techniques, and more.

**330-670-9545**  
**or 216-393-5677**

**Jennifer Judy** x14  
jennifer@todaysbride.com

**Jim Frericks** x16  
jim@todaysbride.com

**Denise Frericks** x15  
denise@todaysbride.com

**Abby Frericks Crowder** x12  
abby@todaysbride.com

## DEADLINES

### TUESDAY, OCTOBER 15, 2025

Final Show Balance Due

### FRIDAY, OCTOBER 24, 2025

Pink Bag "Stuff It" Program Materials Due

Deliver or ship 400 flat pieces to the Today's Bride Office  
3550 Ridgewood Road Fairlawn, OH 44333

**Learn More:** [pros.TodaysBride.com/nov-add](https://pros.TodaysBride.com/nov-add)

### FRIDAY, OCTOBER 31, 2025

Return Credentials Form

**Learn More:** [pros.TodaysBride.com/nov-cred](https://pros.TodaysBride.com/nov-cred)

### WEDNESDAY, NOVEMBER 5, 2025

Order Additional Booth Rental Items

Call Angel at Miller's Party Rental at 330-753-9104 or email  
**amk@millersparty.com** to reserve. Rental fees apply.

### WEDNESDAY, NOVEMBER 5, 2025

Reserve Space and Rentals for the Inspiration  
Galleries (Tables, Gowns, Cakes, Photos)

To reserve space: Contact Abby at 330-670-9545 x12  
or email **abby@todaysbride.com**

To reserve complimentary rentals: Call Angel at Miller's Party  
Rental at 330-753-9104 or email **amk@millersparty.com** to  
reserve.

# MOVE-IN DETAILS & SHOW HOURS

<b>MOVE-IN</b>	Saturday, November 15	10:00 AM - 4:00 PM
	Sunday, November 16	8:00 AM - 10:30 AM
No early move-in without prior approval from Today's Bride.		
<b>SHOW DAY</b>	Sunday, November 16	11:00 AM - 4:00 PM
Silent opening starting at 10:45 AM. Your booth should be ready to go!		
<b>MOVE-OUT</b>	Sunday, November 16	4:00 PM - 7:00 PM
	Exhibitors may begin to dismantle their booth displays (No earlier than 4:00 PM!)	
<b>Tearing down early is prohibited and will result in a \$100 fine and forfeiture of the lead list!</b>		

## CHECK IN

All Exhibitors must check-in at Exhibitor Check-In (Main Entrance, DOOR A) on the NORTH side of the building. A Today's Bride staff member will greet you and direct you to your booth, or to a better unloading door if there is traffic congestion. You will also receive your exhibitor packet and name tags at check-in.

## PARKING

Parking is free in the Summit County Fairgrounds parking lot. Please park on the South side of the building during show days to save North side parking spots for attendees.

## FOOD

During show hours, the Summit County Fairgrounds will have the Snack Shop open. No outside food is permitted to be brought into the building. During move-in hours, you may bring your own food and drinks into the building.

## WI-FI

Wi-Fi is free for exhibitors only. Join the "vendor1" network.  
Password: **Fair1850!**

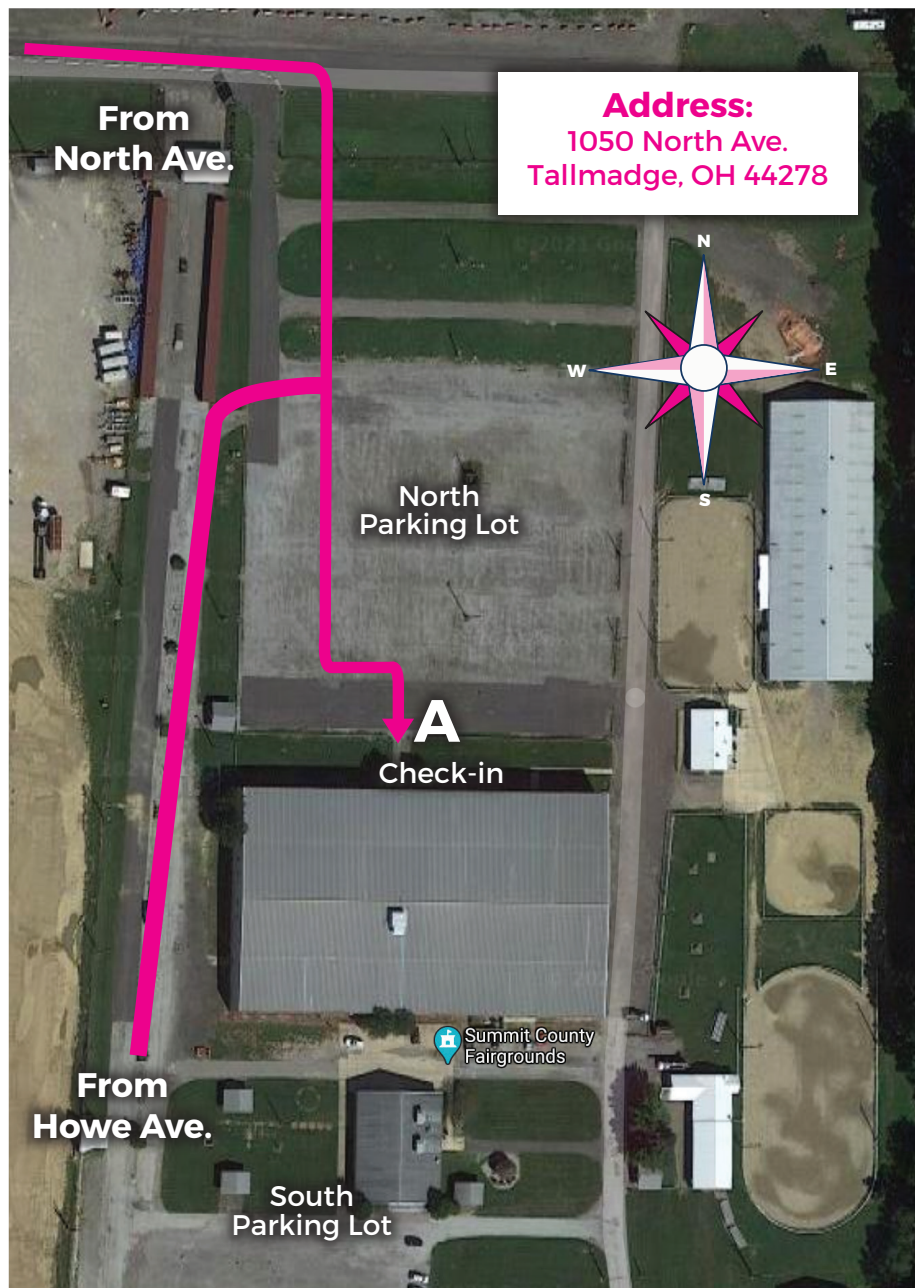

# Today's Bride®

## WEDDING SHOW

Sunday, November 16, 2025  
Summit County Fairgrounds Arena  
Show Hours: 11:00 AM - 4:00 PM

Show Day Exhibitor Help **Hotline**

**440-482-1055**

Need electricity? Trash overflowing?  
Music too loud? Call or text to report  
an issue without leaving your booth!



## PRE-SHOW PREP

### 12 weeks before the show:

- Download the Exhibitor Manual to prepare and track deadlines [pros.TodaysBride.com/November](http://pros.TodaysBride.com/November)
- Set Goals for the Show
  - Number of appointments
  - Testing a new product
  - Taking deposits
  - Signing contracts
- Plan your booth design
  - Layout • Decor • Flooring
  - Banners • Signage • Electric Access
- Order marketing materials: flyers, promo items, samples, show special to offer, literature for brides Pink "Stuff It" Bags (if contracted)

### 4 weeks before the show:

- Stuff-it Bag Materials delivered to Today's Bride by **October 24, 2025**
- Order any extra rentals from a decorator, rental company or venue
- Prepare a way to collect hot leads at the show (guest book, paper or electronic forms)
- Pre-promote your presence at the show: share on social media, website, emails, voicemail & more
- Post online banner images promoting your booth and/or show special. Banners are located on the Exhibitor website: [pros.TodaysBride.com/November](http://pros.TodaysBride.com/November)

### 3 weeks before the show:

- Proof your online listing on [TodaysBride.com](http://TodaysBride.com)
- Audit your design & branding on your website and social media

### 2 weeks before the show:

- Submit your Sign & Nametag Credentials Form by **October 31, 2025**
- Submit your Show Special to post on [TodaysBride.com](http://TodaysBride.com)
- Create a packing list of what to bring to the show (see right)
- Schedule & train your staff on booth etiquette, rules, the sales process, and show specials
- Plan parking and lunch options for your staff
- Prepare the follow-up process (timing of phone calls, emails, direct mail, show special deadlines)
- Review the Exhibitor List online to strategize your networking

## POST-SHOW PREP

### After the show:

- Follow up on your hot leads from the show immediately
- Download the registered attendee list once alerted that it's available
- Continue working the leads throughout the attendees' engagement
- Renew the next show date to keep your online listing active

## PACKING LIST

- ♥ Electrical Cords & Surge Protector
- ♥ Mobile Device Chargers
- ♥ Sales Literature
- ♥ Business Cards
- ♥ Appointment Book
- ♥ Clipboards
- ♥ Booth Design Layout
- ♥ Dolly or Transporting Devices (Suitcase or Wagon)
- ♥ Masking Tape, Scotch Tape, Shipping Tape
- ♥ Scissors, Stapler, Safety Pins, Straight Pins
- ♥ Portable Vacuum/Steamer
- ♥ Pens, Sharpie Marker
- ♥ Trash Bags
- ♥ Aspirin, Band-Aids, Second Pair of Shoes
- ♥ Hand Sanitizer
- ♥ Lead Collection Forms (or laptop/tablet)
- ♥ Breath Mints
- ♥ Good Selling Plan & Attitude

# BOOTH REGULATIONS

## INCLUDED WITH SINGLE FURNISHED BOOTHS & LARGER:

- 8' high BLACK back pipe & drape
- 3' high side rails to separate your booth from neighbors
- 6' rectangle table covered in standard BLACK linen
- 2 chairs, if needed
- Company Name Placement Sign
- Nametags for Staff

\*Tabletop booth includes covered table with black linen and 1 chair.

\*Naked booths do not include a covered table or chairs.

Below are the booth design regulation guidelines. For a SINGLE BOOTH, plan within a 9' x 9' due to vertical poles & bases taking up an extra foot.

1. Displays taller than 8' must get approval from Today's Bride 30 days prior to the show. The backdrop must be tastefully finished on the back side. Property or displays taller than 4' must be placed into the rear half of the exhibit space.

2. Pipes or trusses placed at the front of the booth space are acceptable provided the sides of the space do not obstruct the neighboring booth, and provided there is a clear line of sight from both sides.

Don't position retractable banners at the front of your booth space. Move halfway back or towards the back.

The front five feet of your exhibit may not exceed FOUR FEET in height, unless it's a see-through structure.

3. Stay within the space confines of your booth. Exhibitors are prohibited from standing in the aisles or having their booth displays extend into the aisles.

### Lighting

If you plan to uplight your booth backdrop, you must bring or rent your own pipe & drape backdrop to place in front of the drape that is shared with the exhibitor behind you. The light will show through the thin curtain.

### Pop up Tents & Closed in Structures

(i.e. blow up walk-in photobooth)

Any overhead structure needs to be approved by Today's Bride and the venue. In some cases, the city fire marshall needs to approve the structure as well.

**IMPORTANT: Summit County Fairgrounds and City of Tallmadge does not permit an overhead structure of any kind! This includes pop-up tents.**

Exterior of any part of display facing a booth must be finished or suitably decorated.

Signage may not read into neighboring booths.

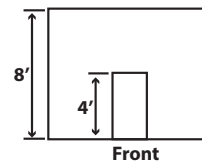
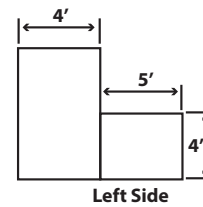
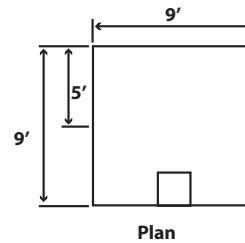
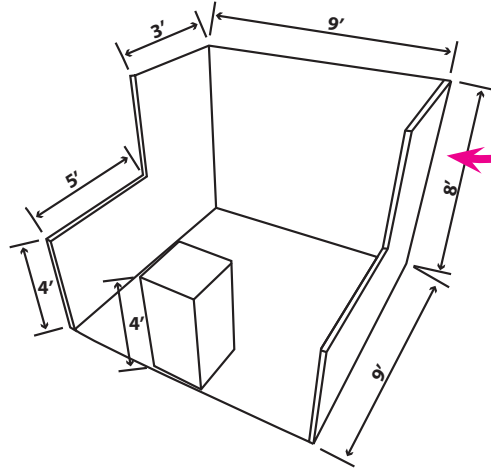

If you are concerned your exhibit is not within the guidelines, give us a call at 330-670-9545. If your exhibit isn't within the guidelines, you will be asked to make changes during move-in.



## Enter To Win!

Enter the RAFFLE to win  
Resin Bookends!

### \$340 Value

On Wednesday January 25th we  
will draw the winner!

We will announce the winner on  
our Instagram so make sure to  
FOLLOW US!

**@SOBLOOM**

Winner does NOT need to be booked with us for their wedding!  
If we are not your florist, you will need to drop off your flowers  
ASAP after your wedding, so that flowers can be properly  
preserved, for the best outcome. More info to come.



# ATTRACT COUPLES TO YOUR BOOTH WITH A SHOW SPECIAL

Show specials are a win-win for both couples & exhibitors at wedding shows! Attendees benefit by scoring deals and saving money, while exhibitors benefit by attracting more attention to their booth. Increase your chance of standing out, generating interest, and getting more leads by offering a limited-time show special.

## NEED INSPIRATION?

### DO YOU WANT SIGNED CONTRACTS?

- ♥ Book today for 10% off
- ♥ Sign this week to save \$100
- ♥ Book this week for only \$1,200
- ♥ Receive a free photo album when you book at the show

### DO YOU WANT MORE BOOTH VISITORS?

- ♥ Spin the wheel for an instant gift
- ♥ Play Plinko for a discount
- ♥ Listen to our demo for a free koozie
- ♥ Stop by our booth for a free catering or cake sample

### DO YOU WANT TO COLLECT MORE LEADS?

- ♥ Enter to win \$500 off any package
- ♥ Enter to win a free overnight stay
- ♥ Schedule an appointment to get \$75 off your gown
- ♥ Enter to win \$200 with any purchase

Let us know about your show promotion and we'll help get the word out by:

- Posting it on the show page on [TodaysBride.com](http://TodaysBride.com).
- Several will be mentioned in an email blast promoting the show and shared on social media

**EMAIL YOUR SPECIALS TO  
[ABBY@TODAYSBRIDE.COM](mailto:ABBY@TODAYSBRIDE.COM)**

or submit it with your credentials form at  
[pros.todaysbride.com/nov-cred](http://pros.todaysbride.com/nov-cred)

## PROMOTE YOUR SPECIAL ON SOCIAL MEDIA

Follow us on:



**TAG us @todaysbride**  
so we can reshare!

# MARKETING UPGRADES

**PINK STUFF-IT BAG PROGRAM \$200\*** DEADLINE OCTOBER 24, 2025



Guarantee every couple goes home with your marketing literature, whether you talked to them or not, by having your literature pre-stuffed in every pink welcome bag. All you need to do is supply us with **400 flyers** by **October 24, 2025**.

**Ship or drop flyers off at:**  
 Today's Bride, 3550 Ridgewood Road Fairlawn, Ohio 44333

- Payment must accompany flyers. • Limited availability for some categories (call for details).
- The flyers **CANNOT** contain names or phone numbers of non-show participating exhibitors.
- The flyers **CANNOT** advertise another bridal show (at your facility or elsewhere).
- The flyers **CANNOT** exceed 10 pages. **No magazines allowed.**
- All flyers must be a single piece item and **FLAT** (call for approval of anything else).

\*must be an exhibitor to qualify for this discounted price.

## TICKET SPONSORSHIPS\*

Elevate your visibility at the show by sponsoring our online ticket sales! Your company logo will be prominently displayed and linked to your website across multiple pages as couples purchase their tickets. This opportunity not only enhances awareness of your presence at the show but also drives traffic to your website leading up to the event!

**PRIMARY DISCOUNT SPONSOR \$800**

**SECONDARY ONLINE SPONSOR \$400**

\*LIMITED SPACE AVAILABLE

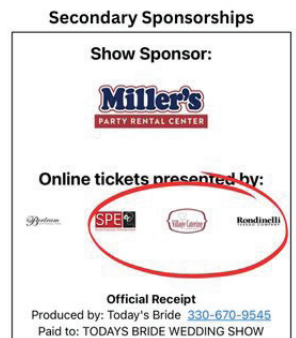
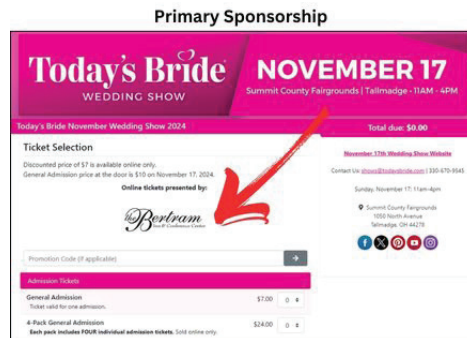

## WEBSITE

Traffic on [TODAYSBRIDE.COM](http://TODAYSBRIDE.COM) increases 30% more before and after the shows. Increase your digital visibility by considering an online upgrade.

**EXHIBITOR LISTING LINK \$100**

**FEATURED EXHIBITOR AD \$150**

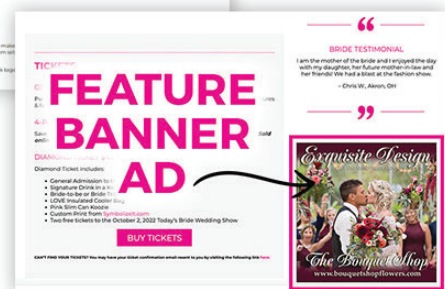

To order a marketing upgrade, visit [pros.TodaysBride.com/nov-add](http://pros.TodaysBride.com/nov-add)

# THE RULES & REGULATIONS

**NOTE: It is your responsibility to understand and abide by these rules.**

Our insurance carrier and facilities instructed us to strictly enforce the show rules and regulations as indicated on your show contract. This will ensure a safe and enjoyable trade show experience not only for participating businesses but, more importantly, our valued attendees. Please read and adjust your presentation and set-up display if necessary.

**Review and share these guidelines with your staff scheduled to work your booth prior to the event.**

1) Booth staff and all display materials **must stay within their contracted booth space** and not infringe upon the aisle walkways or other booth spaces. All aisles must remain clear of obstruction. Maximum backdrop height is 8' tall. The front 5' of your booth may not exceed 4' in height unless the structure is see-through. Backdrops taller must get approval from Today's Bride. Some booth locations are restricted.

2) **Maximum of four staff members** are permitted to exhibit in a single booth space at one time. **Maximum of two staff members** permitted at one time in a Table Top Space.

3) **NO distribution** of any marketing materials is permitted in the event facility, outside of contracted booth space. This includes, but is not limited to: exhibit hall aisles, registration areas, seating areas, rest rooms, parking lot/garage or other event facility grounds.

4) At the Summit County Fairgrounds, **booths are not permitted to have a roof of any kind**, including pop up tents or photo booths. This is in direct violation of the Fire Code.

5) **Distribution of any non-participating, non-contracted business literature (business cards, brochures, signage, etc.) is strictly prohibited.** This includes, but is not limited to, photographs or displays with "courtesy of" acknowledgment of said businesses. The only exception is if the mentioned business is also an exhibitor at the current show.

6) Distributing literature or displaying signage regarding a **competing Bridal Show or Event** (whether at your facility or not) **is strictly prohibited** unless Today's Bride is a sponsor of the event.

7) **Exhibitors MAY NOT begin to take down their booth display prior to show close.** The take down, removal, or repackaging of booth materials and/or displays during posted bridal show hours is strictly prohibited. Any set-up and disassembly must take place prior to guests' arrival and after their exit. You will be held accountable for any injury that may occur as a result of your negligence, forfeit the show's lead list, risk approval to exhibit at future Today's Bride Shows, and be fined \$100. Additionally, guests pay admission for a show advertised with set hours of availability, and we must honor these hours.

8) **No open flames** of any kind permitted in the building.

9) **All food and liquids to be served as samples** must be approved by both the facility and Jadlyn Inc./Today's Bride at least two weeks before the show. Distribution of samples without prior approval is not permitted and may result in dismissal of exhibit space at the show. Sample sizes are restricted to 2oz or less for food, 4oz or less for liquids. Alcohol is strictly prohibited. If using heat for samples, exhibitor must bring a Fire 10# ABC extinguisher to keep at said booth.

10) **During show hours, the Summit County Fairgrounds will have the Snack Shop open. No outside food is permitted to be brought into the building.** During move-in hours, you may bring your own food and drinks into the building.

11) **Distribution of alcoholic beverages, in any form, to attendees is strictly prohibited.**

12) **All audio, video and/or gaming productions must be maintained at appropriate noise levels** so not to infringe on the peace and harmony of neighboring booths. Jadlyn Inc./Today's Bride reserves the right to determine and set the acceptable sound level. Exhibitor is responsible for compliance of all music licensing.

13) Your company/businesses **must provide its own surge-suppressant power strip and extension cord(s)** to use for your trade booth's electrical needs.

14) **The leads generated from this show are for the exclusive use of the exhibitors who made the investment to participate.** The lead lists are seeded. Today's Bride monitors what you are sending. It is a violation of your exhibitor agreement to sell, lend, reproduce, exchange, copy or share the lead list to any non-exhibiting business or non-sponsored show or event that isn't authorized for this list. If this information is used or threatened to be used in an unauthorized manner, Today's Bride shall be entitled to seek relief in any court of competent jurisdiction, including but not limited to injunctive relief, actual and punitive damages, reasonable attorney's fees, costs and any and all other expenses. It is also a violation to use the list or permit the list to be used to promote any other multi-business bridal- or wedding-related show or event, including Client's own participation within such an event, and that damages to Today's Bride for each such use shall be no less than \$3,000.00. (A "use" shall mean each letter, mailing or e-mail sent to an attendee on the lead list). Upon breach of this Contract for any reason, exhibitor's license to use such Lead List shall cease immediately.

15) Exhibitor shall make good any damage to the building or fixtures caused by exhibitor or any of exhibitors' agents or employees. Exhibitors are responsible for any loss of their equipment and/or display material, or personal belongings, resulting from accidental breakage, misplacement, theft, fire or natural disaster, including, but not limited to, damage occurring while Management staff is assisting an exhibitor. If exhibitor uses the services of Management staff, then exhibitor agrees that the staff member is a volunteer for the exhibitor for worker's compensation purposes.

16) The Exhibitor is responsible for insuring its exhibit, personnel, display, automobiles, trailers, and materials against any damage or loss resulting from theft, fire, accidents, or any other cause. The Exhibitor acknowledges and assumes all risks associated with the use of the exhibit space and its surroundings. The Exhibitor agrees not to make any claims, demands, or legal actions against Today's Bride/Jadlyn, Inc, the Show sponsors, or the facility hosting the Show for any loss, damage, or injury incurred by the Exhibitor, its officers, directors, agents, representatives, employees, or their respective property. Neither Today's Bride/Jadlyn, Inc. nor the facility will be liable for the loss or damage of equipment, products, goods, exhibits, or other materials owned, rented, or leased by the Exhibitor, regardless of the cause.

**These and all existing regulations will be strictly enforced.**

**Violation to these regulations may result in the exclusion from future trade shows and/or forfeiture of trade show lead list.**

# GALLERIES

Couples are looking for more inspiration and this show is where they will find it!

Be part of our Inspiration Gallery! Set up any kind of display you want from cakes on a hightop table, gowns and portraits on display, or a full reception table set up to awe and inspire our engaged couples at the show.

## RESERVE SPACE TODAY!

SPACE IS RESERVED ON A FIRST-COME, FIRST-SERVE BASIS

**DEADLINE TO RESERVE: NOVEMBER 5, 2025**

### WHAT YOU NEED TO DO:

- 1. For all galleries:** Contact Abby Frericks Crowder at Today's Bride to reserve your space. You can email her at [Abby@TodaysBride.com](mailto:Abby@TodaysBride.com) or call her at 330-670-9545 x12.
- 2. For the table gallery:** It's a 10' x 10' space. You are responsible for bringing everything needed for the table (i.e. rentals, signage, flowers, etc.) Borrow items at **no extra cost\*** from the gallery sponsor, Miller's Party Rental Center. They offer tables, chairs, linens, flatware and more! To place your order: 330-753-9104 or [amk@millersparty.com](mailto:amk@millersparty.com)

**Deadline to order from Miller's Party Rental Center is November 5, 2025.** Exhibitors are responsible for setting up their display and packing it up during move out.

We encourage collaboration with other exhibitors and will list them on the table sign created by Today's Bride. Any contributing companies must be exhibitors in the show to receive credit. Non-exhibitors may contribute, but their company is not permitted to be promoted on the table or in your exhibit space.

These spaces are for inspiration only. No promotional materials or literature (this includes business cards and signs) will be allowed in the gallery.

Gallery is open to venues, florists, planners, rental companies, or anyone who wants to showcase their design skills of what their business does.

\*Only the gallery items are complimentary. Booth items can be rented for an additional fee.



# PROMO OPPORTUNITIES



## GRAND PRIZE GIVEAWAYS

Donate a prize for Today's Bride to give away as a GRAND PRIZE to a lucky attendee and your business will be mentioned on the show's website, social media posts, and emails.

To be considered, the prize must be a minimum of \$250 and all-inclusive, not a discount or a payment required.

Winners of the prizes will be picked from the show attendees the following week. You will be introduced via email once a winner has been selected.

If you're interested in donating a grand prize, email [shows@TodaysBride.com](mailto:shows@TodaysBride.com) (the sooner the better to maximize your exposure!)



## SHOW SPECIAL AT YOUR BOOTH

Offering a special discount for booking at the show? Or a contest at your booth? We'll help promote that too! Let us know and we'll post it on the show page. Several show specials will be peppered into emails and shared on Social Media.

Email the description of the show special to [shows@TodaysBride.com](mailto:shows@TodaysBride.com).



## POSTCARDS & FREE TICKETS

Each exhibitor will receive postcards in the mail with free ticket promo codes!

We encourage you to pass these free tickets to your clients inviting them to see you at the show. Do not post the codes publicly online! The codes must be redeemed online and will not be accepted at the door.

The ticket codes can be found on the show postcards and have been mailed to you in your Exhibitor Manual packet. Make sure to pass those postcards out!

If you need additional digital codes, please email [shows@todaysbride.com](mailto:shows@todaysbride.com).

## PROMOTE YOUR EXHIBIT (and show special!) before the show to improve your success!

Link to the Today's Bride Facebook page or share the Facebook event.

Tag [@TodaysBride](#) in your posts on Facebook and Instagram for us to share.

Use [#TodaysBride](#) on Instagram posts to start a trend and see other like posts.

Email your prospects inviting them to the show to see your work! Offer to give them free tickets.



[@TODAYSBRIDE](#) // [#TODAYSBRIDE](#)

# EXHIBITOR SERVICES

## AMAZON FAVORITES & SIGNS

Check out our Exhibitor Favorite Products on our amazon storefront:  
**Pros.todaysbride.com/favorite-products**

Items such as tables, tape, carts, & custom design signs/backdrops.

Availability and turnaround is dependent on scheduled production at time of order.



For more samples & ideas visit  
**pros.TodaysBride.com/favorite-products**  
or email [shows@todaysbride.com](mailto:shows@todaysbride.com)

## RENTALS

Miller's is the official decorator for the Today's Bride Wedding Show, offering discounted pricing on various rental items. The items will be placed in your booth space before the show unless you prefer to pick them up at their warehouse beforehand.



Call **330-753-9104**  
Angel, [amk@millersparty.com](mailto:amk@millersparty.com)  
with any questions and to place your order. Deadline to order is **November 5, 2025.**

## PRINT



Looking for help with design and print of show materials? Today's Bride can help you with business cards, brochures, postcards, & more!



**330-670-9545**

Availability and turnaround is dependent on scheduled production at time of order.

## EXHIBITOR WEBSITE

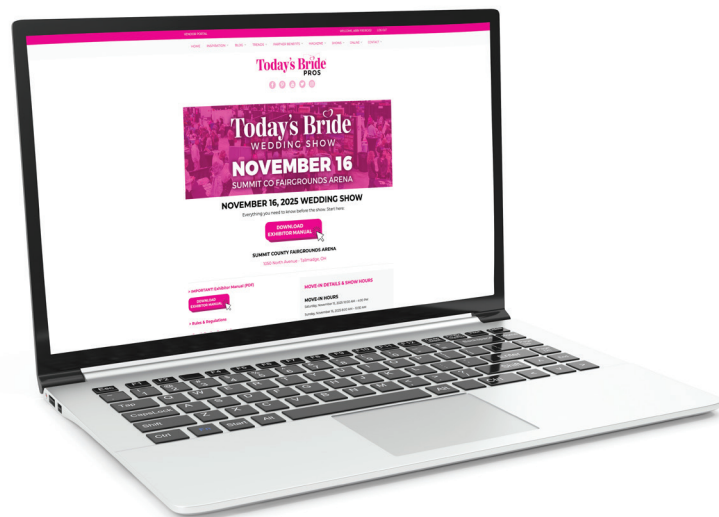

Please find this manual in its entirety plus deadlines, forms, inspiration, and helpful links at

**PROS.TODAYSBRIDE.COM/NOVEMBER**

## We appreciate you taking the time to review the Exhibitor Manual.

We are here to help you any way we can before, during and after the show. Don't hesitate to ask for our input on booth design ideas, marketing techniques and more. **330-670-9545 or 216-393-5677**

**Jennifer Judy x14**  
[jennifer@todaysbride.com](mailto:jennifer@todaysbride.com)

**Abby Frericks Crowder x12**  
[abby@todaysbride.com](mailto:abby@todaysbride.com)

**Jim Frericks x16**  
[jim@todaysbride.com](mailto:jim@todaysbride.com)

**Denise Frericks x15**  
[denise@todaysbride.com](mailto:denise@todaysbride.com)